

UNIVERSITY OF HOUSTON
CULLEN PERFORMANCE HALL

INFORMATION SHEET
(Attachment B)

Additional Information can be obtained at www.uh.edu/cph

INFORMATION CURRENT AS OF
4/5/2006

GENERAL INFORMATION:

DIRECTIONS:

Please see attached map.

STAGE:

Proscenium Height -	22'	Grid Height -	52'
Orchestra Pit Width (DS) -	37'-32"	Stage Height (from seating level) -	3'-7"
Orchestra Pit Width (US) -	30'	Maximum Depression - Orchestra Pit -	4'-6"
Distance from Pit Extension to First Row -	8'-8"	Maximum Depression - Pit Extension -	43"

The orchestra pit is on an electrically-powered screw jack. Loading door is 8'W X 10'H and feeds directly on stage. Loading dock has a 7'-3"W X 9'-0"W scissor jack which lowers from dock level (52" above the stage floor) to stage level. The loading dock is approximately 20" above the pavement level. Pin-rail is 5'-4" off SR - 10' above deck.

There is a more detailed stage layout in the back of this packet on page ##.

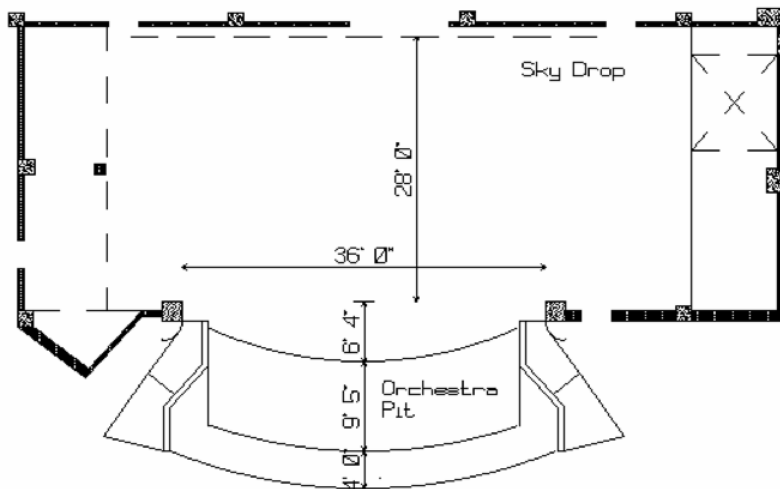

SEATING:

Orchestra: 1038 Balcony: 498 TOTAL: 1536

Cullen Performance Hall has seating available for 8 wheelchairs. Accessible seating may not be sold/distributed to abled-bodied persons until all other seats have been sold/distributed. Please see Cullen Performance Hall Policies on the specifics of this policy (1.14).

The maximum legal capacity of the auditorium is 1536. The maximum legal capacity of the lobby and reception areas is 170 in either area. Public restrooms are located in the lower-level reception area and on the balcony level. There are barrier-free restrooms on the lobby level.

The orchestra pit may be used for seating, but only by specific permission from the Cullen Performance Hall Manager. This seating area allows for an additional 65 seats, bringing the total seats to 1601.

The seating layout of Cullen Performance Hall is on file with Quick Tick and TicketMaster (see phone list on page 9). There is a seating chart at the end of this packet.

DRESSING ROOMS:

<u>Location</u>	<u>#</u>	<u>Capacity</u>	<u>Toilets</u>
Stage Level	3	5 ea.	Adjacent
Second Floor	1	12-15	Yes
Second Floor	1	20-24	Yes

All dressing rooms have wardrobe racks, makeup lights, and hot & cold running water. There are two showers in the basement, adjacent to the green room.

STAGEHANDS:

Cullen Performance Hall does *not* have an IATSE contract. Local stagehands are available. Cullen Performance Hall does utilize LOCAL 51 for additional staff when a call may not be filled by the available in house staff. The minimum call for all activities in Cullen Performance Hall is one Stagehand, plus a Cullen Performance Hall House Manager and three Ushers on performance days. Please see Cullen Performance Hall Policies for specific staffing requirements.

<p>If stagehands are required to work longer than 5 hours without a 1-hour meal break, the promoter will pay the stagehands <u>double</u>-time until they are given a 1-hour break.</p> <p><u>No</u> activities may occur in the theater while stagehands are on break.</p> <p>The pay rate will be 1.5 times the prevailing rate for any hours worked in excess of 8 hours within a 24-hour period. In addition, the stagehand rate will be 1.5 times the prevailing rate for any hours worked on Sundays and between the hours of 12:00 a.m. and 8:00 a.m. Professional ushers and non-uniformed security are available to augment the uniformed security furnished by the University of Houston Police Department. Please contact the Cullen Performance Hall manager for details.</p>

AIRPORTS:

Houston is served by two major airports. Hobby Field (HOU) is approximately 20 miles closer to the University of Houston than is Houston Intercontinental (IAH). From Hobby, take Broadway to Interstate 45 North and follow the directions on the attached map. From Intercontinental, follow the signs to US 59 South, as you approach downtown Houston take the Interstate 45 South exit.

BANKING:

The closest bank is:

Sterling Bank
4600 Gulf Freeway
Houston, Texas
(713) 923-4600

There is also a branch of Woodforest National Bank in the University Center, one building away from Cullen Performance Hall. Their phone number is 713-743-1080.

CATERING:

There are various catering services available to furnish food and beverage to audience members and/or backstage personnel. Please contact the Cullen Performance Hall Manager for details.

Serving of food and/or beverages to performance patrons requires special permits and additional cleaning deposits. If you are planning on serving food and/or beverages at your event please let the Cullen Performance Hall Manager know as soon as possible. This is to insure the necessary approvals and permits are obtained prior to your event. Also, all beverages (sold or given away) must be a Coca-Cola product due to the exclusive contract the University of Houston has with Coca-Cola.

The lower-level reception area is equipped with an icemaker and drink cooler.

HOTEL / RESTAURANT ACCOMMODATIONS:

The University has a hotel, the Hilton University of Houston Hotel, on campus, less than a block from Cullen Performance Hall. Their phone number is (713) 741-2447. Although they do not offer a group or corporate rate, their regular rates are quite reasonable. The hotel has two restaurants that are open for breakfast, lunch, and dinner.

There are also dining facilities available in the University Center, across the street from the hotel. In addition, there are various restaurants, fast-food places, etc., within easy driving distance.

LAUNDRY/DRY CLEANING:

The nearest laundry facility is Fred's Washateria and Dry Cleaning, in the 5000 block of Scott Street, approximately 1.5 miles from Cullen Performance Hall.

MEDICAL:

For non-life-threatening emergencies on weekdays between 8AM and 8PM go to the University Health Center, 2 buildings away from Cullen Performance Hall. At other times, we recommend Hermann Hospital, 6431 Fannin (corner of MacGregor). Their phone number is 713-797-4011. For life-threatening emergencies the Houston Fire Department Paramedic number is: 713-222-3434. For non-emergency medical needs, a physician referral can be obtained from the University Health Center at 713-743-5151.

MUSICAL EQUIPMENT:

Cullen Performance Hall has a 7' Kawai grand piano. We suggest that the presenter engage the services of a piano tuner on the day of performance. Cullen Performance Hall does NOT provide tuning of the piano. There are 45 music stands and 83 musician's chairs available. There are no stand lights available. Cullen Performance Hall does not charge additional rental fees for their use, but does appreciate timely notice if you require their use.

PARKING:

Special arrangements must be made for the unloading and parking of trucks and busses. These arrangements can be made through the Cullen Performance Hall Manager. Performers and staff members who will require on-campus parking during regular business hours must have permits. See the Cullen Performance Hall Manager for details. Please see the building / lot map at the end of this packet for specific areas you may park.

TECHNICAL INFORMATION:

ELECTRICAL:

Location of Company Switch: DSR

There are two available disconnects: (3 phase, 208v N + G)

- 1. 200A/leg – (AUDIO) on isolation transformer (also feeds house sound)
- 2. 500A/leg – (LIGHTING) also feeds house switchboard and work and houselights

House switchboard:

ETC Expression 3x – 800 channels, 600 cues, 500 groups, 24 submasters (with 10 pages of submaster memory), and a trackball.

House Control:

DMX 512 (5 pin at Light Console and Dimmer Packs – 3 pin for fogger and moving lights)
(there is a 5pin line at stage right that gets changed to 3pin for the fogger and moving lights)
House Lighting control is independent of the light console.

The house system is dimmer-per-circuit. The house connector is 20A, 3-conductor stage pin connector.

House circuits are distributed as follows:

FOH 5.....120-131	FOH 4.....98-112	FOH 3.....114-119
SL Box Boom #2.....142-146	SR Box Boom #2.....132-136	SL Box Boom #1.....147-151
SR Box Boom #1.....137-141	#1 Electric.....1-27	#2 Electric.....28-36
#3 Electric.....37-45	#4 Electric.....46-63	#5 Electric.....152-166
#6 Electric.....64-81	SR Drop Box #1.....82-85	SL Drop Box #2.....90-93
SR Drop Box #3.....171-174	SL Drop Box #4.....183-186	SL Drop Box #1.....86-89
SL Drop Box #2.....94-97	SR Drop Box #3.....167-170	SR Drop Box #4.....175-178
SL Drop Box #5.....179-182	USR Floor.....187-189	FOH and SR Rail.....113, 193-204

The three circuits in the USR floor are 50 amp circuits with 3-20 amp branches apiece; the 50 amp circuits do not have actual 60amp stage pin connectors (yes this is stupid). As noted above, circuit 113 and circuits 193-204 feed multi-cables in both backstage and the front-of-house.

LIGHTING EQUIPMENT:

Please see attached fixture inventory.

15' Booms: 4 Sidearms: 27 Crow's feet: ... 12

There are various high-hats and barndoors.

Additional lighting equipment is available locally for rental or purchase. (see phone number list on page 8)

Cyberlights - 2 (mounted on balcony rail) *****additional fee applies*
Technobeams - 2 (mounted on USR and USL boxbooms) **** *additional fee applies*

F-100 Fogger w/ DMX control (controlled through lightboard)

SOUND EQUIPMENT:

Main house mixer is a Yamaha M2500 (48+4stereo x 8x8x3), with 48 balanced input channels (mic or line-level) and 4 stereo input channels. All mono inputs have a 4-band EQ with two sweepable mid-bands. Stereo inputs have a 2-band shelving EQ. There are 14 auxiliary buses with 3-14 switchable between pre- or post-fader operation. All channels can be assigned to any of the 8 groups, stereo, or center buses. Mono channels can be set to LR pan or LCR pan. There is also a 13x8 Matrix that allows the 8 groups, stereo, center, and L and R sub inputs to be mixed to 8 discrete outputs. The console is also equipped with a 128 mute scene memory.

The 3 house main ceiling clusters, balcony fill, and 4 stage monitor/effects channels are all processed by DBX Driveracks. These components do all EQ, crossover, limiting, delaying, and compressing for the speaker systems. They are computer controlled and can be adjusted to allow the sound engineer to fine tune the room for the specific sound being created. Each ceiling cluster covers the entire house and is tri-amplified. The low frequency speakers are JBL 225J drivers in JBL 4508 enclosures. The mid-range speakers are JBL 2445J drivers with JBL 2380 horns (90 X 40). The high frequency speakers are JBL2404H drivers. The sub speakers are EAW SB625P. Monitor speakers consist of four JBL Cabaret 4602B and two other JBL (model unknown). There are a total of 60 microphone or line-level circuits (12 SL, 12 SR, 12 Orchestra Pit, 6 Ceiling, 6 booth).

AUDIO RACK COMPONENTS:

- 2 – Sony MDS-E12 Mini-Disc Player
- 1 – Tascam 302 Dual Cassette Deck (both decks play and record)
- 1 – Denon DN-D4000 Dual CD Player
- 1 – Yamaha REV 100 Effects Processor
- 1 – Yamaha REV 500 Effects Processor
- 1 – JVC FX-330 Digital Tuner (am/fm radio)
- 2 – Drawmer MX30 2 Channel gated/compressor/limiter
- 1 – Dell Computer – WinXP (2.0 GHz, 512MB Ram, 80Gig HD)
w/ Card Deluxe Sound Card (balanced in/out, Digital I/O RCA)
- 1 – Quasar VHS Stereo VCR
- 1 – Denon DN-V300 Pro DVD Player

PORTABLE RACK COMPONENTS:

- 1 – Teac CD-P1440 CD Player
- 1 – Tascam 130 Cassette Deck

MICROPHONES:

1	AKGD320B	Dynamic Cardioid
1	AKGD330BT	Dynamic Cardioid
3	Audio Technica ATM31	Cardioid Condenser
1	Audio Technica ATM31R	Cardioid Condenser
3	Audio Technica 815R	Shotgun Condenser
6	Audio Technica ATPRO45	Hanging Condenser
3	Crown PCC-160	Cardioid Condenser (floor mount)
1	Electro-Voice DL-42	Dynamic Cardioid
1	Electro-Voice 644	Dynamic Shotgun
1	Electro-Voice 666-R	Dynamic Cardioid
1	Electro-Voice RE50	Dynamic Omnidirectional
2	Electro-Voice RE55	Dynamic Omnidirectional
3	Sennheiser MD421-U-5	Cardioid Condenser
1	Sennheiser e 602	Dynamic Cardioid (kick mic)
6	Sennheiser e 604	Dynamic Cardioid (clip on drum, ect.)
5	Shure SM 57	Dynamic Cardioid
10	Shure SM 58	Dynamic Cardioid
1	Shure SM 58 w/switch	Dynamic Cardioid
4	Shure SM 81	Cardioid Condenser

WIRELESS MICRPPHONES: (ADDITIONAL FEE APPLIES)

6	Shure ULX1	Body-Pack Transmitter
4	Shure WL184	Supercardioid Condenser (for above body-pack)
4	Shure WL185	Cardioid Condenser (for above body-pack)
4	Shure Guitar/Instrument Cable	Instrument Cable (for above body-pack)
6	Shure ULX2 w/SM 58 Head	Handheld
2	Shure ULX2 w/SM Beta58A Head	Handheld
8	Shure ULXP	Receiver Unit

***** Although CPH has 14 wireless microphones – ONLY 8 may be used at one time (i.e. 8 receivers)*****

AUDIO CABLE:

10	15' XLR Cable (M/F)	24	25' XLR Cable (M/F)
15	50' XLR Cable (M/F)	3	75' XLR Cable (M/F)
1	100' XLR Cable (M/F)	10	Short 1/4" TR Cable
4	25' 1/4" TR Cable	10	10' Insert Cables (1/4"
3	75' 12 Channel, 6 return XLR Snakes	1	50' 6 Channel XLR Snake

ADDITIONAL AUDIO EQUIPMENT:

- 6 Whirlwind Director Direct Boxes
- Assorted Adaptor Cables and Adaptors

COMMUNICATION:

The intercom is a two-channel Clear-Com system, and stations can be installed wherever necessary. There are wall stations installed in all the dressing rooms, green room, and production office back stage in addition to the front office and Technical Director's office. The Light Booth, Sound Booth, and Stage Manager's Panel backstage all have stations that allow the user to communicate on both intercom channels. In addition the Light Booth and SM Panel have announce buttons on their stations that input into the backstage monitoring/paging system.

13	Clear-Com 501 Beltpacks	5	Silver Clear-Com Beltpacks (old school)
12	Single Muff Headsets	6	Double Muff Headsets
3	Light Weight Single Muff Headset	1	'Telephone' Handset
8	25' Cable	6	50' Cable
2	100'	1	Flashing / Tone Call Indicator

ADDITIONAL INFORMATION

MASKING (Please see attached house line schedule):

Hanging Goods

1	Grand Drape	1	Valence
5pr.	Flat Black Legs	3	Flat Black Borders
2	Full-Stage Black Drape	1	Black Scrim
1	White Leno Filled Scrim		

Goods in Storage

1	White Leno Filled Scrim	1	Flat Black Drape (11'W X 24'H)
1pr.	Flat Black Leg (4'W X 25'H)	1	Black Drape (14'W X 25'H)
1pr.	Flat Black Leg (8'W X 25'H)		

RISERS:

Cullen Performance Hall has 4' X 8' Wenger stage risers in the following heights and quantities:

#	<u>Height</u>
4	24"
3	16"
4	8"

DANCE FLOOR:

Cullen Performance Hall has a full-stage black/gray Rosco dance floor. It takes approximately 30 minutes to lay the dance floor out on the stage floor and secure it with tape.

CULLEN PERFORMANCE HALL LINE SCHEDULE

Line #	Distance From Plaster Line	House Goods	Purchase
1	1'-0"	GRAND VALANCE (40'W X 6'H)	DP
2	2'-0"	GRAND DRAPE (2@ 21'W X 23'H)	SP
3	2'-6"	#1 Black Legs (8'W X 24'H)	DP
1ST ELECTRIC			Winch 1
4	4'-0"		DP
5	4'-6"		SP
6	5'-0"		SP
7	5'-6"		DP
8	6'-0"	(currently unavailable)	DP
2ND ELECTRIC			Winch 2
9	7'-0"	#2 Black Legs (8'W X 24'H)	DP
10	7'-6"	#1 Black Border (40'W X 9'H)	SP
11	8'-0"	PROJECTION SCREEN	DP
12	----	(does not exist)	----
3RD ELECTRIC			Winch 3
13	10'-6"		DP
14	11'-0"		DP
15	11'-6"	#3 Legs (12'W X 24'H)	DP
16	12'-6"		DP
17	13'-0"		DP
4TH ELECTRIC			Winch 4
18	---	***S.L. TAB ELECTRIC *** NOT AVAILABLE***	SP
19	15'-0"	#2 Black Border (40'W X 9'H)	DP
20	15'-6"	#1 Black Velour (2 @ 27'W X 24'H) (MID BLACKOUT)	DP
21	16'-6"	#4 Black Legs (12'W X 24'H)	DP
22	17'-0"		SP
23	17'-6"		SP
24	18'-0"	Mirror Ball	SP
25	19'-0"		DP
26	19'-6"		SP
5TH ELECTRIC			Winch 5
27	22'-0"	#3 Black Border (40'W X 9'H)	DP
28	22'-6"	#5 Black Legs (12'W X 24'H)	DP
29	23'-0"	BLACK SCRIM (40'W X 26'H)	DP
6TH ELECTRIC			Winch 6
30	24'-6"		DP
31	25'-0"		DP
32	25'-6"		DP
33	27'-0"		DP
34	27'-6"	#2 Black Velour (3@ 14'W X 24'H) (US BLACKOUT)	DP
35	28'-0"	WHITE LENO FILLED SCRIM (40'W X 26'H)	DP

Grid Height.....52'

Proscenium Height22'

Maximum Trim of Single Purchase (SP) Linesets42'

ALL HOUSE GOODS MUST BE RESTORED TO THIS SCHEDULE AT STRIKE

**UNIVERSITY OF HOUSTON
CULLEN PERFORMANCE HALL**

Phone Numbers

NOTE: The listings below are for the convenience of Cullen Performance Hall users only and do not constitute an endorsement by the University of Houston or Cullen Performance Hall of any particular product or service.

EMERGENCY:

Houston Fire Department Paramedics 713-222-3434
University of Houston Police Dept. (Emergency) 713-743-3333

OTHER NUMBERS:

MEDICAL:

Hermann Hospital 713-797-4011
University of Houston Health Center 713-743-5151

UNIVERSITY OF HOUSTON:

Cullen Performance Hall Administrative Office 713-743-5186
Cullen Performance Hall Manager 713-743-5192
Cullen Performance Hall Box Office 713-743-5188
Cullen Performance Hall Technical Director 713-743-5191
Cullen Performance Hall Production Office (backstage) 713-743-5109
Cullen Performance Hall Fax 713-743-5194
University of Houston Police (Information) 713-743-0600
University of Houston Hilton Hotel 713-741-2447
Parking and Transportation Services 713-743-1097

THEATRICAL SUPPLIES:

Bayou City Backdrop Co (backdrops) 713-862-5917
Bright Star Productions (light / sound rental) 713-529-2757
J & S Audio Visual 713-957-4567
LD Systems (sound and lighting sales/rental) 713-695-9400
Performing Arts Supply 713-681-8688
StageLight (lighting rental and theatrical supplies) www.stagelight.com 713-942-0555
Swank Audio-Visual 713-659-5444
Tobins Lake Studios (backdrops) www.tobinslake.com 810-229-6666

OTHER:

Evans Music City 713-781-2100
Giesler Broadcasting Supplies 713-774-3314
Grainger Industrial Supply 713-783-9012
Guitar Center 713-952-9070
Gulf Coast Electric 713-222-9086
Quick Tick www.quicktick.com 713-849-2528
TicketMaster www.ticketmaster.com 713-586-6314
Riggsbee Hardware (Wholesale) 713-224-6734
Radio Shack 713-665-7491
Yellow Cab Company 713-236-1111

CULLEN PERFORMANCE HALL LIGHTING FIXTURES

FRONT-OF-HOUSE FIXTURES *:

#	USED IN HOUSE PLOT	TYPE	FIELD ANGLE	LAMP	GEL SIZE	B Dia. @ 60'	FC. @ 60'
11	11	ETC Source 4	19 degree	HPL 575x	6.25" x 6.25"	6.3' @ 30'	262 @ 30'
23	23	ETC Source 4	10 degree	HPL 575x	12.4" x 12.4"	7.2'	220

ONSTAGE FIXTURES *:

#	USED IN HOUSE PLOT	TYPE	FIELD ANGLE	LAMP	GEL SIZE	B Dia. @ 30'	FC. @ 30'
3	0	ETC Source 4	19 degree	HPL 575x	6.25" x 6.25"		
24	24	ETC Source 4	26 degree	HPL 575x	6.25" x 6.25"	9'	160
49	49	ETC Source 4	36 degree	HPL 575x	6.25" x 6.25"	12.3	77
10	9	ETC Source 4	50 degree	HPL 575x	6.25" x 6.25"	18.9	36
6	6	Strand #2212 6 X 12	11 degree	EHG	7.5" x 7.5"	13.2'	168
2	2	Altman 6 X 22	9 degree	FEL	7.5" x 7.5"		
9	9	12" Fresnel	14/60 degrees	CYX	14.25" x 14.25"	7.4'/25'	428/25
36	33	ETC PAR		HPL 575x	7.5" x 7.5"		

ADDITIONAL FIXTURE BARRELS:

#	USED IN HOUSE PLOT	TYPE	FIELD ANGLE
1	0	ETC Source 4	10 degree
3	0	ETC Source 4	19 degree
0	0	ETC Source 4	26 degree
6	0	ETC Source 4	36 degree
5	0	ETC Source 4	50 degree

CYCLORAMA FIXTURES:

#	USED IN HOUSE PLOT	TYPE	LAMP	GEL SIZE	FC. @ 5'
8	8	Colortran #108-412 (3-circuit Far-Cyc)	FFT	15"H x 16"W	600
3	3	Strand 4-circuit Coda	FDN	10" x 9"	92
3	3	Strand 3-circuit Coda	FDN	10" x 9"	92

MOVING FIXTURES / INTELLIGENT LIGHTING: (ADDITIONAL RENTAL FEE APPLIES)

2	2	Highend Technobeam (no iris) w/ laser
2	2	Highend Cyberlight

There is one 16" mirror ball.

*** "Front-of-House" and "Onstage" refer to typical usage; fixtures may be moved as needed – BUT MUST BE RESTORED TO THE STANDARD PLOT AT STRIKE.**

University of Houston
Cullen Performance Hall
Seating Chart

1536 - Orchestra + Balcony

1520 seats
 16 accessible seats

1601 - Orchestra + Balcony

+ **Orchestra Pit**
 1585 seats
 16 accessible seats

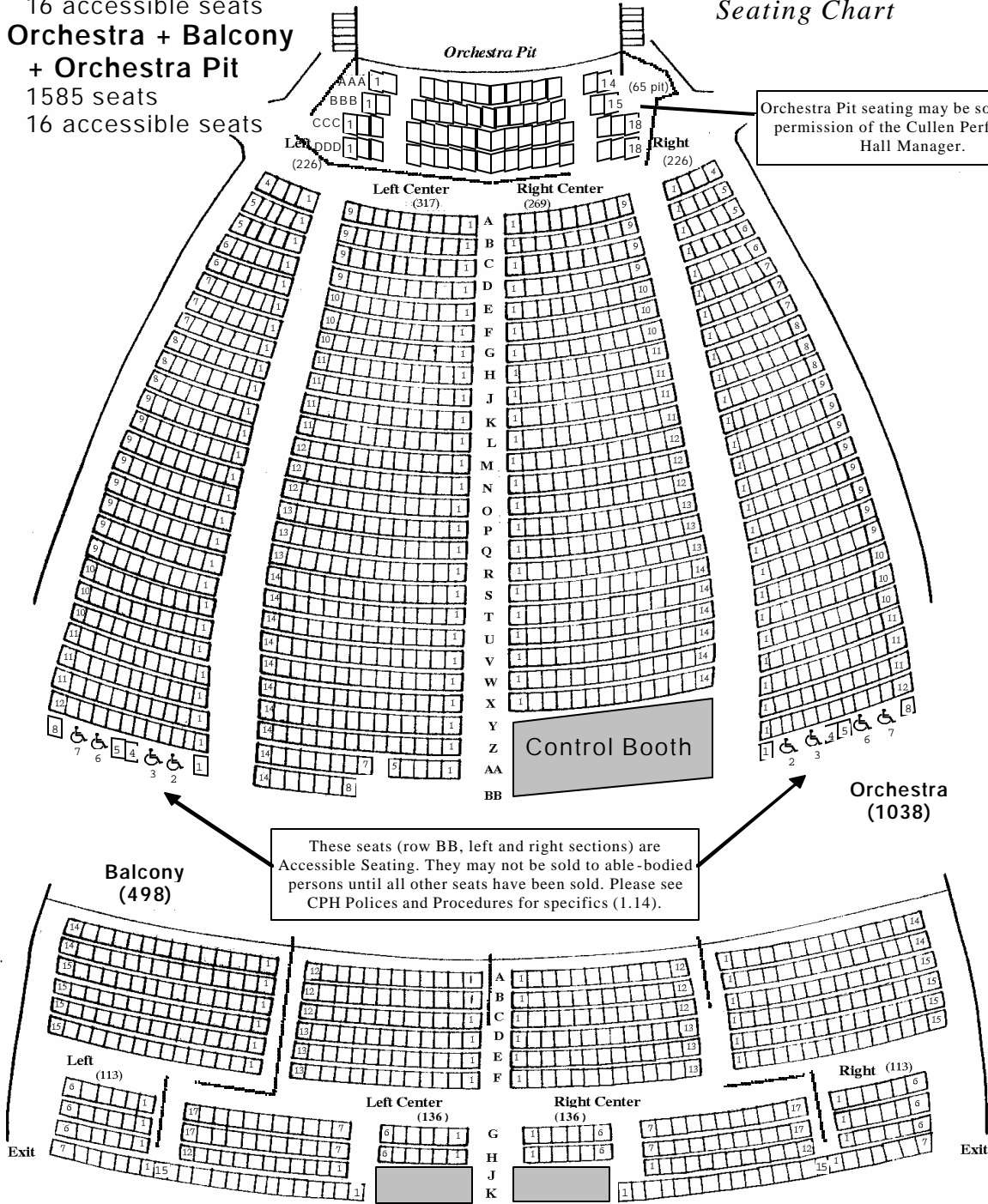

Orchestra Pit seating may be sold only by permission of the Cullen Performance Hall Manager.

These seats (row BB, left and right sections) are Accessible Seating. They may not be sold to able-bodied persons until all other seats have been sold. Please see CPH Policies and Procedures for specifics (1.14).

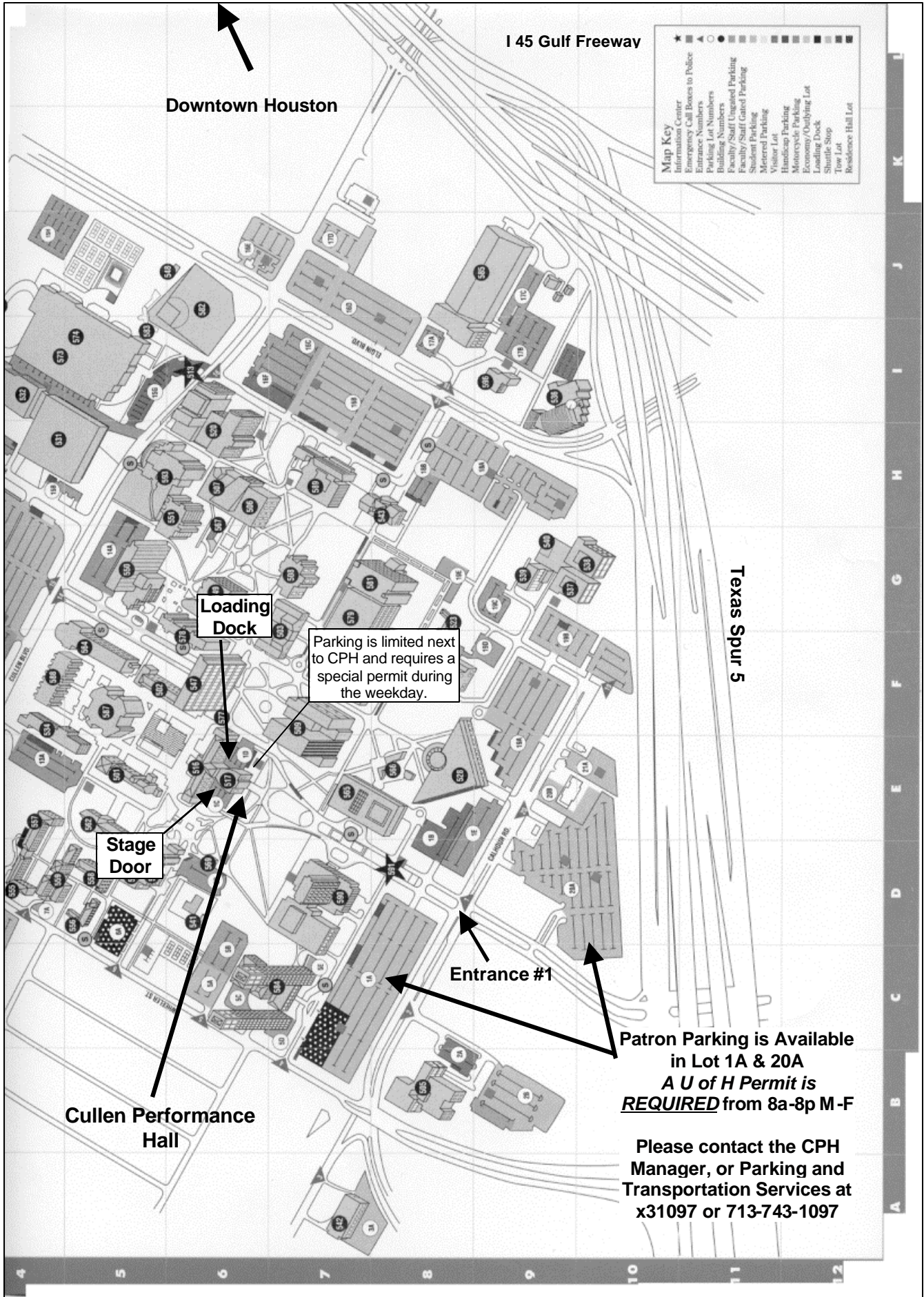

Directions to University of Houston Cullen Performance Hall

COMING FROM I-45 TRAVELING SOUTH (FROM DOWNTOWN)

Take I-45 South and Exit Spur 5

At the First Stop Light, 'UH University Drive', take a Right.

At the Next Stop Light, 'Calhoun', continue going straight.

(This is Entrance 1 to the University)

Cullen Performance Hall is at the very end of the road.

Parking is available in the large parking garage BEFORE the Hilton Hotel on the Left

(Parking is limited next to the building)

COMING FROM I-45 TRAVELING NORTH (FROM GALVESTON)

Take I-45 North and Exit Elgin Blvd.

At the First Stop Light, 'Elgin Blvd', take a Left.

Drive under the bridges.

At the Second Stop Light, 'TO Alt 90' (spur 5 feeder road), take a Left.

(The University is now on your Right)

At the Next Stop Light, 'UH University Drive', take a Right.

At the Next Stop Light, 'Calhoun', continue going straight.

(This is Entrance 1 to the University)

Cullen Performance Hall is at the very end of the road.

Parking is available in the large parking garage BEFORE the Hilton Hotel on the Left

(Parking is limited next to the building)